



COMMERCIAL DESIGN GUARANTEED PERFORMANCE

FOOD PROCESSOR

Instruction & Recipe Booklet

Please read these instructions carefully and retain for future reference



LC9000

Contents

Congratulations	4
Sunbeam's Safety Precautions	5
Features of your Café Series® Food Processor	6
Attachments for your Café Series® Food Processor	8
Using your Café Series® Food Processor	9
Fitting/using the tools on your Café Series® Food Processor	11
Storing your Café Series® Food Processor	13
Handy hints for processing	15
Care and cleaning	17
Recipes	18

Important instructions – retain for future use.

تأكد من تفهم احتياطات السلامة المذكورة اعلاه

請務必理解上述的安全預防措施。

Assurez-vous que les précautions ci-dessus relatives à la sécurité sont bien comprises

Versichern Sie sich, dass die obenstehenden Sicherheitsmaßnahmen verstanden werden

Βεβαιώστε πως οι παραπάνω προφυλάξεις ασφαλείας γίνονται κατανοητές

Pastikan bahwa tindakan-tindakan keselamatan seperti di atas dimengerti anda

Accertatevi che le suddette norme di sicurezza siano comprese a dovere

上記の注意事項をよくお読みになり、安全を御確認ください

Уверете се дека погоре споменатите мерки на претпазливост се добро разбрани

Asegúrese de que las precauciones de seguridad precedentes sean bien comprendidas

کاری بکنید که احتیاطهای بالا حتماً درک بشوند

ต้องแน่ใจว่า ข้อควรระวังเรื่องความปลอดภัยข้างต้น เป็นที่เข้าใจกันดี

Yukarda belirtilen güvenlik önlemlerinin anlaşıldığından emin olunuz

Xin kiểm chắc rằng những biện pháp làm an toàn kể trên được hiểu rõ

Congratulations

Congratulations on the purchase of your Sunbeam Café Series® Food Processor. The Sunbeam Café Series® delivers quality, style and superior performance capturing the essence of the commercial kitchen.

Inspired by heavy-duty equipment found in restaurants, cafes and bars, the Sunbeam Café Series® is built to last. It brings together a range of appliances designed to expertly create authentic café food and beverages at home.

Uncompromising blends of stainless steel, chrome and die-cast alloy characterise the range. This combined with advanced technology and functional design, guarantee the performance, that each product will surpass expectations.

The Sunbeam Café Series® Food Processor is designed with quality components, a die-cast metal base and includes a number of features, to create a versatile addition to your kitchen.

Sunbeam's Safety Precautions

SAFETY PRECAUTIONS FOR YOUR SUNBEAM FOOD PROCESSOR LC9000.

- Always use extreme care when handling blades and cutting discs. These are extremely sharp and may cause injury if handled incorrectly. Always store blades and cutting discs in their respective covers or processing containers.
- Unplug from power outlet when not in use, before putting on or taking off attachments, and before cleaning.
- Do not put hot liquids into the processing bowl. Cool to room temperature before placing in processing bowl.
- Avoid contacting moving parts at all times.
- Place the processing bowl onto the base of the processor before fitting any attachments.
- All blades and attachments should be removed with care before cleaning.
- Do not over fill the processor.
- Do not process for longer than the time periods recommended in the operating chart.
- Always remove the blade before emptying the processing bowl of its contents.
- Do not operate for more than 30 seconds at a time when processing heavy loads. None of the recipes in this manual are considered a 'heavy load'.
- Take care when removing the bowl from the base, emptying the bowl or during fitting and removal of blade system, as blades are extremely sharp.

Sunbeam is very safety conscious when designing and manufacturing consumer products, but it is essential that the product user also exercise care when using an electrical appliance. Listed below are precautions which are essential for the safe use of an electrical appliance:

- Read carefully and save all the instructions provided with an appliance.
- Always turn the power off at the power outlet before you insert or remove a plug. Remove by grasping the plug - do not pull on the cord.
- Turn the power off and remove the plug when the appliance is not in use and before cleaning.
- Do not use your appliance with an extension cord unless this cord has been checked and tested by a qualified technician or service person.
- Always use your appliance from a power outlet of the voltage (A.C. only) marked on the appliance.
- This appliance is not intended for use by persons (including children) with reduced physical, sensory or mental capabilities, or lack of experience and knowledge, unless they have been given supervision or instruction concerning use of the appliance by a person responsible for their safety.
- Children should be supervised to ensure that they do not play with the appliance.
- The temperature of accessible surfaces may be high when the appliance is operating.
- Never leave an appliance unattended while in use.
- Do not use an appliance for any purpose other than its intended use.
- Do not place an appliance on or near a hot gas flame, electric element or on a heated oven.
- Do not place on top of any other appliance.
- Do not let the power cord of an appliance hang over the edge of a table or bench top or touch any hot surface.
- Do not operate any electrical appliance with a damaged cord or after the appliance has been damaged in any manner. If damage is suspected, return the appliance to the nearest Sunbeam Appointed Service Centre for examination, repair or adjustment.
- For additional protection, Sunbeam recommend the use of a residual current device (RCD) with a tripping current not exceeding 30mA in the electrical circuit supplying power to your appliances.
- Do not immerse the appliance in water or any other liquid unless recommended.
- Appliances are not intended to be operated by means of an external timer or separate remote control system.
- This appliance is intended to be used in household and similar applications such as: staff kitchen areas in shops, offices and other working environments; farm houses; by clients in hotels, motels and other residential type environments; bed and breakfast type environments.

If you have any concerns regarding the performance and use of your appliance, please visit www.sunbeam.com.au or contact the Sunbeam Consumer Service Line.

Ensure the above safety precautions are understood.

Features of your Café Series® Food Processor

Processing cover

The processing cover or lid of bowl provides a safety feature to the appliance. The appliance will not operate unless the bowl, cover and large feed pusher are correctly positioned and locked into place.

1400 watt induction motor

The die-cast base houses a powerful 1400 watt motor. This motor is ideal for high load applications during processing, and provides a greater starting strength whilst maintaining speed throughout. The Café Series® Food Processor motor is reliable, quiet, will provide a long life and is backed by a 10 year guarantee.

START/STOP button

For easy use the START/STOP button starts and stops the operation of the food processor.

Auto Pulse

The Auto Pulse function is a clever and versatile feature providing short bursts of processing, for a set length of time. Creating bread or biscuit crumbs couldn't be easier.

Pulse

The control panel includes a Pulse function for optimum cutting precision during processing.

Storage drawer

The unique drawer design enables attachments to be stored conveniently, and safely, within the appliance when not in use.

Non-slip feet

Keeps the food processor secure on the bench top during use.

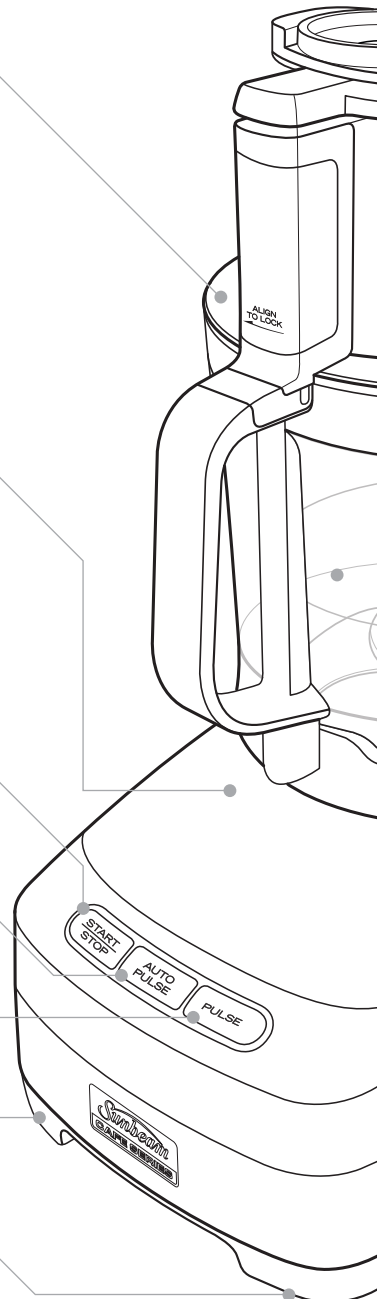

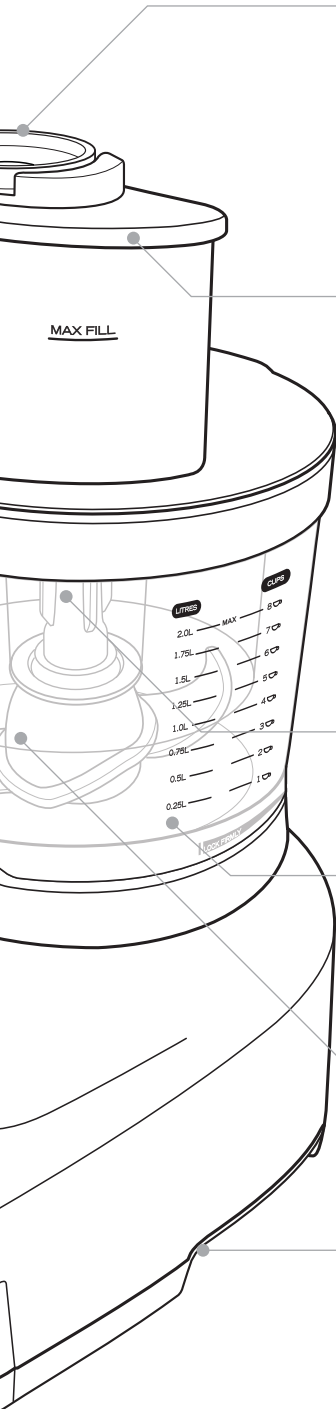

Food Pushers

The food pushers assist in guiding the food through the chute to ensure ingredients hit the blade vertically for best processing results. Three food pushers are included, depending on the size of the chute being used and the size of foods. For thinner foods, use the smaller internal pusher for consistent even slicing. This pusher also doubles as a measuring cup.

Wide Chute

At 14cm's wide, the extra wide chute eliminates the need to cut most ingredients, to fit into the chute. Guide ingredients through the chute into the selected blades. Additional ingredients can be added during other processing tasks.

Chute Safety Feature

The wide chute pusher provides a safety interlock feature to the appliance. The motor will not operate unless the bowl and lid are correctly locked in position, and the large feed pusher is inserted.

Spindle

Drives all the food processing attachments. The spindle must be in place to operate the food processor.

Processing bowl with handle

Large 2 litre capacity processing bowl. The handle of the processing bowl includes a patent-pending robust stainless steel interlock that prevents food catching and building up, ensuring easy cleaning.

Second processing bowl

The smaller processing bowl is ideal for small amounts of ingredients. At 400ml in volume, this bowl is perfect for chopping nuts, creating pesto or chopping herbs.

Cord storage facility

For added convenience the unused cord length can easily be pushed into the base of the processor for storage.

Attachments for your Café Series® Food Processor

1. Universal 's' blade

Stainless steel smooth edged processing blade is designed for cutting, kneading, whisking and emulsifying. The second smaller 's' blade is suitable for the smaller bowl.

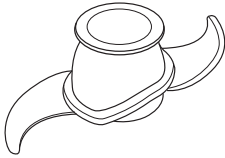

2. Variable slicing blade

The variable stainless steel slicing blade allows foods to be sliced to a variety of thicknesses, up to 7mm. This blade can not be used in the small processing bowl.

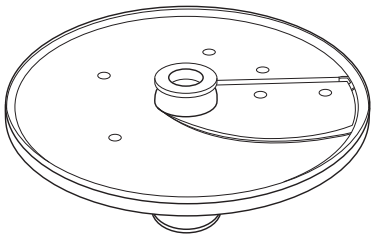

3. Julienne disc

The stainless steel julienne blade is perfect for achieving consistent julienne cut food, perfect for salad, stir fry or garnishing.

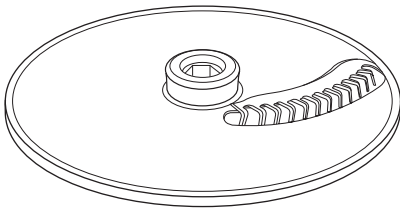

4. Reversible shredding disc - fine and coarse

Ideal control, the reversible stainless steel shredding blades allow for the choice of fine or coarse results.

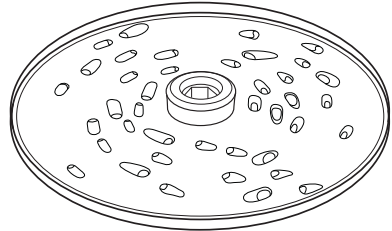

5. Reversible grating and shaving disc

Unique to processing is the shaving blade. It does lovely thin flakes, great for parmesan and sweet potato crisps. The alternate side is ideal for hard cheeses and chocolate.

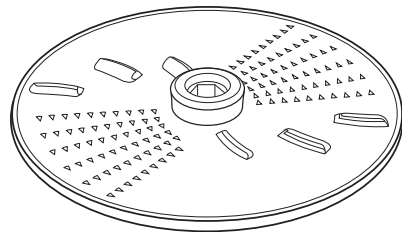

Using your Café Series® Food Processor

- Before using your Café Series® Food Processor, familiarise yourself with all parts, remove all promotional and packaging materials. Use caution when handling blades, as blades are sharp.
- Wash the processing bowl, processing cover and all attachments in warm water using a mild detergent. Dry each part thoroughly before use.
- Before you assemble the food processor, ensure that the power cord is unplugged.

1. Place the motor base facing you on a dry, level surface.
2. Place the processing bowl onto the motor base, the bowl will only sit correctly on the base when the handle is positioned to the right, see figure 1.

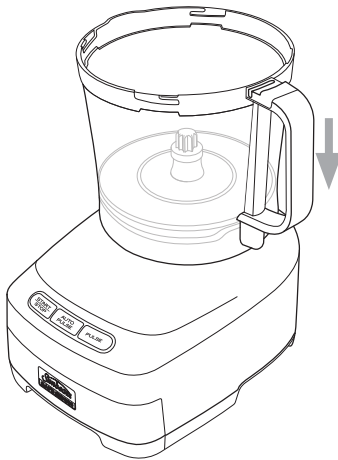

Fig 1

3. Rotate the handle clockwise to lock, as indicated by the graphics on the left side of the motorbase, see figure 2.



Fig 2

4. Position the lid onto the processing bowl. You will notice a solid grey line on the left of the holding lip on the lid, when placing the lid onto the bowl this arrow needs to align with the solid grey line on the handle of the bowl. To lock, turn the lid clockwise, as indicated by the graphics, on the top of the handle, see figure 3.

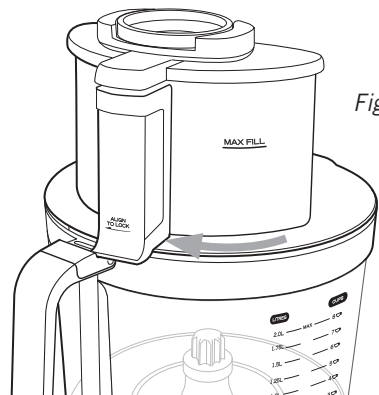

Fig 3

Using your Café Series® Food Processor continued

Important: If the processing bowl, processing cover and large pusher are not correctly assembled, the food processor will not operate. This is a safety feature.

Using your Food Processor

1. Plug the power cord into a 230-240V AC power outlet and turn the power 'ON'.
2. Using the START/STOP button on the control panel, press once to start processing.

The Pulse function remains on as long as the Pulse button is pressed down.

The Auto Pulse function will run for a predetermined length of time.

Further ingredients can be added whilst the appliance is running by pouring through the medium or small feed tube once the food pusher/s have been removed. Removing the large pusher will stop the motor running.

3. After you have completed processing, press the START/STOP button to stop processing.

Note: For maximum control, load the feed tube before turning on your food processor. Always use the food pusher for more evenly processed foods and never push with your fingers.

Important: The food processor is fitted with a safety thermal cut-out device and will shut off in the event of overload. If this occurs, switch the appliance off and it will automatically reset when cool.

Fitting/Using the tools on your Café Series® Food Processor

Note: All attachments must be firmly attached to the spindle. Always adjust the attachments until you are sure that they are correctly fitted.

Placing the spindle

1. Fit the spindle onto the drive shaft, see figure 4.

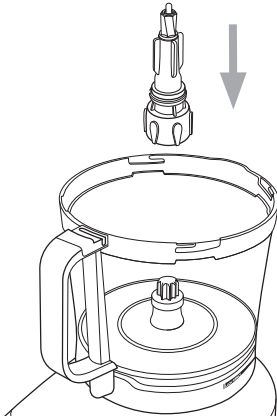

Fig 4

3. Place food into the processing bowl.
4. Fit the processing cover to the processing bowl, see figure 3 and place the food pusher in the feed chute.
5. Plug the power cord into a 230-240V AC power outlet and turn the power 'ON'.
6. Start processing using the START/STOP or Pulse buttons.
7. When processing is complete, remove the spindle and blade from the processing bowl before removing the processed food.

Universal 's' Blade

1. Fit the processing bowl and spindle as detailed previously in figures 1, 2 & 4.
2. Fit the universal 's' blade over the spindle and press firmly into place, see figure 5.

Warning: Use caution, as blades are sharp. Always handle the processing blade by its central plastic section.

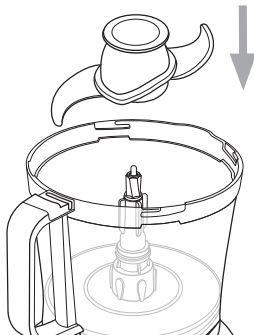

Fig 5

Fitting/Using the tools on your Café Series® Food Processor continued

Reversible grating/shaving, shredding and julienne discs

1. Fit the processing bowl and spindle as detailed previously, in figures 1, 2 and 4.
2. Select the 'Reversible' disc of your choice – Shredding (fine or coarse), Grating/Shaving or the dedicated Julienne disc.
3. Fit the disc over the spindle and press firmly into place, see figure 6.

Warning: Use caution as the blades are sharp.

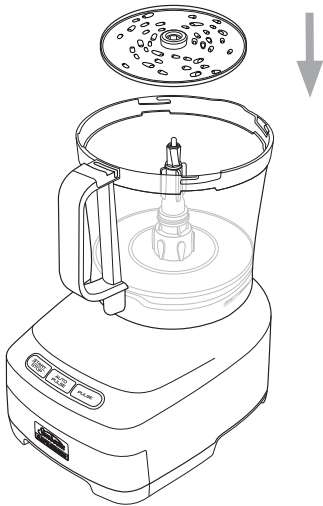

Fig 6

4. Fit the processing cover to the processing bowl as previously shown in figure 3 and place the food pusher in the feed chute.
5. Plug the power cord into a 230-240V AC power outlet and turn the power 'ON'.
6. Start processing using the START/STOP button.
7. When processing is complete, remove the disc and spindle from the processing bowl before removing the processed food.

Variable slicing blade

1. Fit the processing bowl and spindle as detailed previously in figures 1, 2 and 4.
2. Fit the slicing disc over the spindle and press firmly into place, see figure 7.



Fig 7

Warning: The variable slicing blade can be used in the large processing bowl only. Do Not use the variable slicing blade in the small bowl.

Warning: Use caution as the blades are sharp.

3. Fit the processing cover to the processing bowl as previously shown in figure 3 and place the food pusher in the feed tube.
4. Plug the power cord into 230-240V AC power outlet and turn the power 'ON'.
5. Start processing using the START/STOP button.
6. When processing is complete, remove the disc and spindle from the processing bowl before removing the processed food.

Storing your Café Series® Food Processor

The Café Series® Food Processor was designed so that all attachments can be stored within the unit itself, see figure 8.



Fig 8

Storage drawer

The 'Julienne Blade', 'Reversible Shredding' disc, 'Reversible Grating and Shaving' disc are all stored in the storage drawer.

1. Slide out the storage drawer at the base of the food processor.
2. Place the small universal 's' blade at the rear of the drawer as indicated in figure 9.

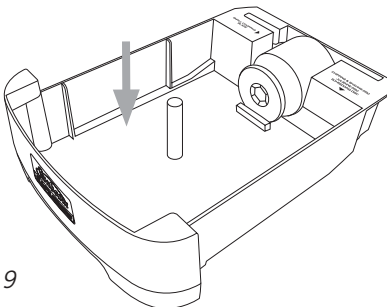

Fig 9

3. Place one of the 'Reversible discs' in storage drawer as indicated in figure 10.

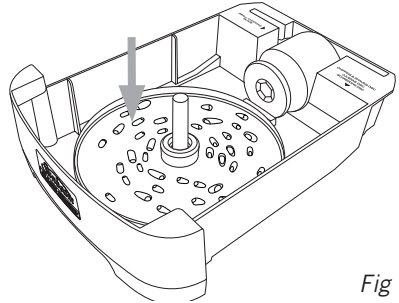

Fig 10

4. Place the 'Julienne Disc' in the storage drawer as indicated in figure 11.

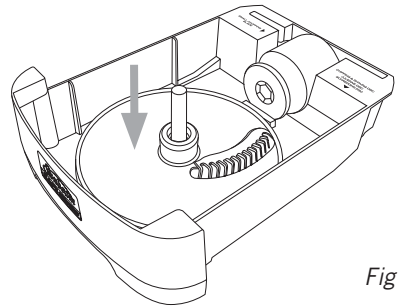

Fig 11

5. Place the remaining 'Reversible Disc' in on top of the first 'Julienne Disc' as indicated in figure 12.

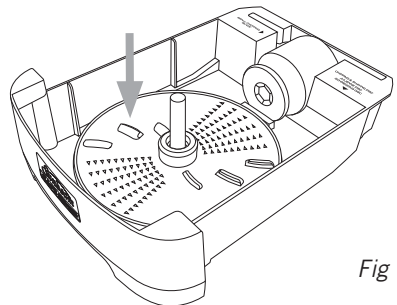

Fig 12

Storing your Café Series® Food Processor continued

6. Close storage drawer, see figure 13.

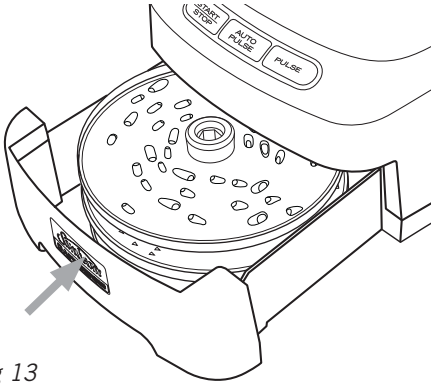

Fig 13

Processing bowl storage, see figure 14.

1. Place the processing bowl onto the base of the food processor.
2. Fit the spindle over the drive shaft.
3. Fit the large universal 's' blade over spindle.
3. Place the small bowl inside the large bowl.
4. Place the 'Variable Slicing' blade over the spindle and then fit the processing cover to the processing bowl.

Cord storage

The power cord can be stored by pushing it into the back of the motor base, see figure 15.

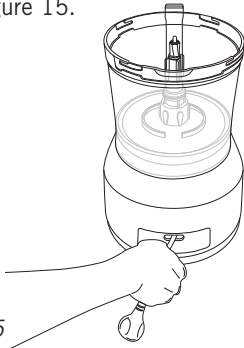

Fig 15

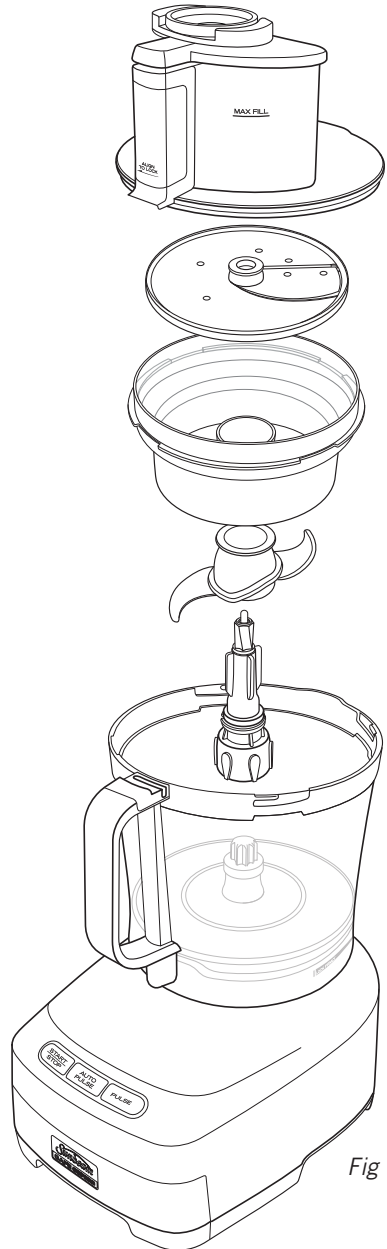

Fig 14

Handy hints for Processing

Chopping

For the best, most consistent results, you should try to process pieces of food that are approximately equal in size. When you break, cut or tear food into uniform pieces before you begin processing, the finished results will be more uniform.

More consistent processing results are achieved if the container is not overloaded.

Mincing

Pre-cut meat into cubes approximately 2cm square.

Vegetables

When processing vegetables such as onions, peel and quarter or cut large vegetables into eighths.

Mixing

The quantities that can be processed within the Processing bowl will vary with the density of the mixture.

For best results with cheese

Softer cheeses such as Cheddar or Swiss should be well chilled before processing. For best results with harder cheeses such as Parmesan or Romano, use the shaving disc, with the cheese at room temperature.

Note: When grating parmesan cheese do not apply a lot of pressure to the food pusher.

Soups

When preparing soups, always allow ingredients to cool to room temperature, before processing.

Adding Ingredients

When various recipes require dry ingredients such as flour, add them directly into the processing bowl before processing. There is no need to sift ingredients when using your food processor. Liquid ingredients may be added while the processor is operating by pouring through the feed tube in the processor cover.

Note: When processing sauces or semi-liquid ingredients, stop the food processor and scrape down the container sides with the spatula provided.

Using the Feed Tube

The most important factor for successful slicing and shredding is the way in which the food is packed into the feed tube.

When slicing, shredding, shaving or grating

Cut all ingredients to a size that fits comfortably into the feed tube. Pack the feed tube and, while holding food steady and upright with the food pusher, press down evenly until all ingredients are sliced or shredded. The more firmly you push, the thicker the slices or shreds. Do not use excessive force or you may damage the food processor.

Note: Never use fingers to push food down the feed tube. Always use the food pusher.

For best results when slicing

The feed tube should always be packed firmly to allow each piece of food to support the others. There will always be a small portion of food left unprocessed between the food pusher and the blade.

Handy hints for Processing continued

Preparing longer slices

Pack food items horizontally in the feed tube, see figure 16.

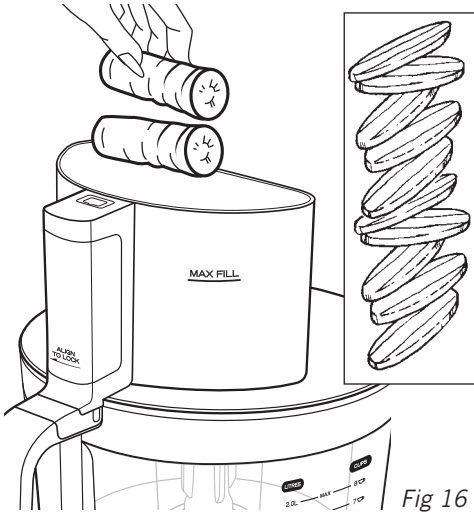

Fig 16

Food Pusher

Use the food pushers to help guide food through the chute for even, consistent processing. Use the smaller food pushers for smaller, thinner foods for best results.

Note: Always wait for the universal 's' blade or any attachments to stop moving completely before removing the processing cover.

Warning: Use extreme caution, as blades are sharp. Always handle the universal 's' blade by its central plastic section.

Warning: The variable slicing blade can be used in the large processing bowl only. Do Not use the variable slicing blade in the small bowl.

Preparing shorter slices

Pack the food items vertically in the feed tube, see figure 17.

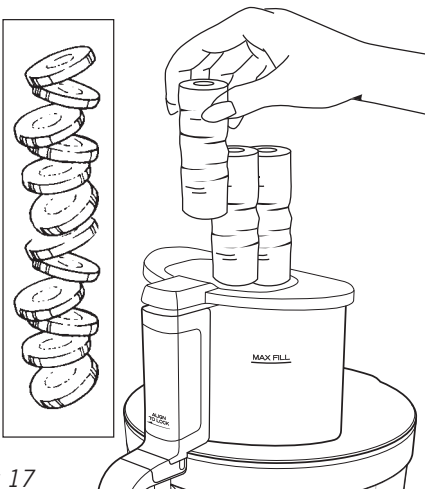

Fig 17

Care and cleaning

When you have finished processing, unplug the Café Series® Food Processor from the power outlet.

All accessories and processor tools can be washed in hot soapy water except for the processor body. Clean the processor body by wiping with a damp cloth.

Warning: Care must be taken when handling the metal blades as these items are extremely sharp.

Note: Always unplug the Café Series® Food Processor before cleaning.

Dishwasher Use

All plastic components deteriorate through the prolonged use of a dishwasher for cleaning.

We do not recommend to place any parts of the food processor in the dishwasher.

If using the dishwasher, place parts only on the top rack of your dishwasher. Do not place any parts in the bottom racks. This may cause plastic parts to distort due to the heating element in the dishwasher.

Recipes - Pastry & Dough

Basic White Loaf

Makes: 1 loaf

½ cup warm milk

¼ cup warm water

1 tablespoon caster sugar

1 teaspoon yeast

1 ¾ cups plain flour

60g butter, melted

1 teaspoon salt

1. In a small bowl combine milk, water, sugar and yeast. Allow to stand in a warm place until mixture begins to foam.
2. Using the large bowl fitted with the large universal 's' blade, add flour, butter, salt and yeast mixture. Process until dough forms a ball.
3. Turn dough out onto a lightly floured surface and knead gently.
4. Place dough into a greased bowl, cover and allow to rise in a warm place until doubled in size. This will take approximately 30-40 minutes.
5. Preheat oven to 180°C. Lightly grease a loaf pan.
6. Punch down the dough and place in loaf pan.
7. Bake for 30 minutes and until loaf sounds hollow when the base is tapped

Pizza Dough

⅓ cup lukewarm milk

2 teaspoons yeast

1 teaspoon caster sugar

2 cups plain flour

2 teaspoons salt

1 egg

60g butter, melted

1. In a small bowl combine milk, yeast and sugar. Allow to stand in a warm place until mixture begins to foam.
2. Using the large processing bowl fitted with universal 's' blade process flour, salt, egg and butter.
3. Add yeast mixture to the bowl and press auto pulse. Place dough onto a floured surface and knead gently until smooth.
4. Place in a greased bowl, cover and allow to rise in a warm place until doubled in size about 30-40 minutes.
5. Turn dough out of bowl and halve. Roll into two 26cm circles.

Pastry & Dough continued

Short Crust Pastry

2 cups plain flour

125g butter, room temperature

1 egg yolk

1 tablespoon iced water

1. Using the large processing bowl fitted with the large universal 's' blade process flour, butter, egg yolk and water until mixture forms a ball.
2. Knead pastry until smooth shaping into a disk. Wrap pastry in plastic wrap and refrigerate for 30 minutes before use.

Sweet Short Crust Pastry

2 cups plain flour

½ cup icing sugar

125g butter, room temperature

2 egg yolks

1 tablespoon iced water

1. Using the large processing bowl fitted with the large universal 's' blade process flour, icing sugar, butter, egg yolks and water until mixture forms a ball.
2. Knead pastry until smooth then shape into a disk. Wrap pastry in plastic wrap and refrigerate for 30 minutes before use.

Pastry & Dough continued

Olive and Rosemary Focaccia Bread

Makes: 1 loaf

1 cup lukewarm water

2 teaspoons yeast

1 teaspoon caster sugar

4 cups plain flour

2 teaspoons salt

$\frac{2}{3}$ cup olive oil

$\frac{1}{2}$ cup kalamata olives, pitted

2 tablespoons fresh rosemary leaves

Salt and freshly ground black pepper, to taste

1. In a small bowl combine water, yeast and sugar. Allow to stand in a warm place until mixture begins to foam.
2. Using the large processing bowl fitted with the large universal 's' blade, process flour and salt. Add yeast mixture with half of the oil. Select Auto Pulse.
3. Shape dough into a ball and place in a greased bowl, cover. Allow to stand in a warm place until dough has doubled in size approx. 30-40 minutes
4. Lightly grease 2 rectangular baking trays. Preheat oven to moderately hot 180°C.
5. Roll each portion of dough on a lightly floured surface to about 1cm thick. Place on prepared baking trays.
6. Cover and allow to rise for about 30 minutes. Using your knuckles, press small indents into the dough. Brush with remaining oil and sprinkle with olives, rosemary and salt. Bake for 30 minutes or until golden.

Dips & Sauces

Chimmichurri

This is a great sauce for steaks or any grilled meat.

Makes: 2 ½ cups

- 1 bunch fresh flat leaf parsley
- 2 cloves garlic
- ½ red onion
- ½ cup olive oil
- ¼ cup red wine vinegar
- 2 teaspoons lemon juice
- 1 teaspoon fresh oregano
- Salt and freshly ground black pepper, to taste

1. Using the small processing bowl fitted with the small universal 's' blade process parsley, garlic and onion until roughly chopped.
2. Add remaining ingredients through the small chute and process until all ingredients are finely chopped. Season to taste with salt and pepper.
3. Store in a clean, covered container in the refrigerator for up to one week.

TIP: This sauce is also great for marinading. Marinade meat in half of the chimmichurri then serve with the remaining sauce.

Basil and Cashew Pesto

Spread on a thick piece of bread for a quick snack.

Makes: 2 cups

- 1 bunch fresh basil
- 1 bunch fresh flat-leaf parsley
- 1 clove garlic
- 1 ½ cups cashew nuts, roasted
- 1 cup baby spinach
- ⅓ cup olive oil
- 1 tablespoon lemon juice
- Salt and freshly ground black pepper, to taste

1. Using the large processing bowl fitted with the large universal 's' blade process all ingredients until roughly chopped. Season to taste with salt and pepper.
2. Store in a clean, covered container in the refrigerator for up to one week.

Dips & Sauces continued

Hummus

Makes: 2 cups

2 400g cans chickpeas, drained, rinsed

1 clove garlic

½ cup olive oil

1 tablespoon lemon juice

1 tablespoon tahini

¼ cup water

Salt and freshly ground black pepper, to taste

1. Using the small processing bowl fitted with the small universal 's' blade process all ingredients, excluding water, until a smooth paste. With motor running slowly add water until desired consistency. Season to taste with salt and pepper.

2. Store in a clean, covered container in the refrigerator for up to one week.

TIP: Add a teaspoon of your favourite ground spice for a twist.

Satay Sauce

Makes: 2 cups

1 cup peanuts, roasted

½ cup vegetable oil

2 cloves garlic

1 long red chilli, deseeded

½ red onion

1 tablespoon dark soy sauce

2 teaspoons brown sugar

1 teaspoon shrimp paste

¾ cup water

1 tablespoon lemon juice

Salt and freshly ground black pepper, to taste

1. Using the small processing bowl fitted with the small universal 's' blade process peanuts, oil, garlic, chilli and onion until a chunky paste is formed.

2. Cook paste over medium heat for 1-2 minutes or until fragrant. Add, soy, sugar and shrimp paste cooking for a further minute. Add remaining ingredients to the pan, whisking to combine. Bring to a simmer and cook for 15-20 minutes or until slightly thickened. Season to taste with salt and pepper.

3. Store in a clean, covered container in the refrigerator for up to one week.

Dips & Sauces continued

Roasted Beetroot Dip

Makes: 3 cups

3 large beetroot

1 clove garlic

2 tablespoons olive oil

1 tablespoon lemon juice

½ teaspoon ground coriander

½ teaspoon ground cumin

Salt and freshly ground black pepper, to taste

1. Preheat oven to 180°C.
2. Place whole beetroot in the middle of a square of tinfoil with garlic and half of the olive oil. Bring edges of tinfoil together to form a parcel. Place in oven and bake for 30-40 minutes or until beetroot are tender.
3. Once beetroot have cooled, rub the skin off and cut in half.
4. Place all ingredients into the large processing bowl fitted with the large universal 's' blade. Process until smooth. Season to taste with salt and pepper.
5. Store in a clean, covered container in the refrigerator for up to one week.

Sweet and Sticky Barbecue Sauce

This sauce is great served on burgers or barbecued meats.

Makes: 2 ½ cups

¼ cup vegetable oil

1 clove garlic

1 onion

1 red capsicum, deseeded

2 tablespoons dark rum

¼ teaspoon ground allspice

¼ teaspoon ground cloves

1 cup tomato sauce

½ cup water

⅓ cup brown sugar

¼ cup American mustard

¼ cup apple cider vinegar

¼ cup molasses

1 teaspoon Tabasco sauce

Salt and freshly ground black pepper, to taste

1. Using the large processing bowl fitted with the large universal 's' blade process oil, garlic, onion and capsicum until a fine paste.
2. Cook paste over medium heat until softened. Add rum, allspice and cloves, cooking until fragrant. Add the remaining ingredients and stir occasionally for 20 minutes or until thickened.
2. Store in a clean, covered container in the refrigerator for up to one week.

Dips & Sauces continued

Mayonnaise

Makes: 2 cups

4 egg yolks

1 tablespoon white wine vinegar

2 teaspoons Dijon mustard

2 ¼ cups vegetable oil

Salt and freshly ground black pepper, to taste

1. Using the small processing bowl fitted with the small universal 's' blade process egg yolks, vinegar and mustard until combined.
2. With the motor running slowing add the oil in a slow stream. Season to taste with salt and pepper.
3. Store in a clean, covered container in the refrigerator for up to one week.

Variations:

- Garlic Mayonnaise- Preheat oven to 180C. Wrap a head of garlic in tinfoil. Place in oven and bake for 30-40 minutes or until garlic is tender. Squeeze out the garlic cloves from the skin and add to finished mayonnaise. Press Auto Pulse. Season to taste with salt and pepper
- Cheats Tartar Sauce - To the completed mayonnaise add 4 medium gherkins, ½ small red onion, ¼ cup capers, ¼ cup fresh flat-leaf parsley and 2 tablespoons lemon juice. Using the auto pulse button allow to run one cycle. Season to taste with salt and pepper.
- Herbed Mayonnaise add - To the completed mayonnaise add 1 tablespoon lemon juice, 2 teaspoons fresh chives, 2 teaspoons fresh dill and 2 teaspoons fresh flat leaf parsley. Press Auto Pulse. Season to taste with salt and pepper.

Salads

Asian Coleslaw

Serves: 4-6

2 carrots, peeled

1 red onion

½ Chinese cabbage

½ red cabbage

1 cup bean sprouts

1 tablespoon rice wine vinegar

1 egg yolk

½ cup vegetable oil

2 tablespoons lime juice

2 tablespoons sweet chilli sauce

¼ cup peanuts, roasted

Fresh coriander, to garnish

Salt and freshly ground black pepper, to taste

1. Using the large processing bowl fitted with the julienne blade julienne carrot. Set aside.
2. Set the variable slicing blade to 1mm and slice onion. Set aside.
3. Set the variable slicing blade to 7mm and slice the Chinese cabbage through the wide chute. Reduce the variable slicing blade to 4mm and slice the red cabbage.
4. In a large bowl combine all sliced vegetables and bean sprouts.
5. Using the small processing bowl fitted with the small universal 's' blade add vinegar and egg yolk. Slowly add oil in a thin stream until a thick dressing has formed. Add lime juice and sweet chilli sauce. Pulse to combine. Set aside.
6. Place peanuts in the small processing bowl fitted with the small universal 's' blade and press Auto Pulse.

7. Pour dressing over the salad gently tossing for an even coating. Season to taste with salt and pepper. Top with coriander and crushed peanuts.

Shaved Fennel Salad

Serves: 3-4

2 small fennel bulbs

2 large zucchinis

⅓ cup lemon juice

⅓ cup olive oil

¼ cup fresh dill, roughly chopped

1 tablespoon honey

200g baby rocket

½ cup pine nuts, roasted

150g feta cheese, crumbled

Salt and freshly ground black pepper, to taste

1. Using the large processing bowl fitted with the variable slicing blade set to 3mm, process the fennel. Set aside.
2. Using the large bowl fitted the julienne blade, slice the zucchini into threads. Set aside.
3. In a small bowl combine dill, lemon juice, oil and honey. Season to taste with salt and pepper.
4. In a large bowl combine remaining ingredients. Pour over dressing and toss to combine.

Salads continued

Smoked Salmon Salad

This salad is great for an afternoon snack!

Serves: 2

1 English cucumber

1 bunch radishes

1 red onion

¼ cup olive oil

2 tablespoons freshly chopped dill

2 tablespoons lemon juice

1 teaspoon honey

250g smoked salmon

Salt and freshly ground black pepper, to taste

1. Using the large processing bowl fitted with the variable slicing blade to 3mm, process the cucumber lengthways to form thin long slices. Repeat with radishes and red onion. In a large bowl toss cucumber, radish and red onion.
2. In a small bowl combine oil, dill, lemon juice and honey. Season to taste with salt and pepper.
3. Add salmon, pour over dressing and toss to combine. Serve.

Mains/Sides/Soups

Vegetarian Lasagne

Serves: 8-10

- Olive oil spray
- 2 eggplants
- 2 large zucchinis
- 2 medium sweet potatoes, peeled
- 1 large red onion
- 1 red capsicum, deseeded
- ½ cup semi dried tomatoes
- ¼ cup fresh basil, chopped
- 800g can crushed tomatoes
- 50g butter
- ¼ cup plain flour
- 3 cups milk
- 200g mozzarella cheese grated
- 50g parmesan cheese grated
- 4 fresh lasagne sheets
- Salt and freshly ground black pepper, to taste

1. Preheat oven to 200°C. Grease 2 baking trays with oil spray.
2. Using the variable slicing blade to 4mm, process eggplant lengthways in the large chute to form thin long slices. Repeat this process with zucchini, sweet potato and red onion.
3. Spread sliced vegetables over baking trays and bake for 20-25 minutes or until golden and tender.
4. Using the large processing bowl fitted with the universal 's' blade process capsicum, semi dried tomatoes, basil and crushed tomatoes until a smooth paste. Season to taste with salt and pepper.

5. In a medium saucepan melt butter. Whisking add flour to form a paste. Slowly add milk, stirring constantly to prevent lumps forming. Cook until sauce has thickened. Remove from heat and stir through mozzarella.
6. In a greased baking dish layer roasted vegetables, tomato sauce, white sauce and lasagne sheets. Repeat. Top with a layer of white sauce and parmesan cheese.
7. Place in oven and bake for 20-30 minutes or until cheese is melted and lasagne sheets are cooked.

TIP: This lasagne can be frozen and reheated.

Mains/Sides/Soups continued

Herb Crusted Chicken

Serves: 4-6

10 slices white bread

1 clove garlic

1 tablespoon fresh chives

1 tablespoon fresh flat leaf parsley

2cm piece lemon rind

8 chicken thigh fillets

2 cups plain flour

4 eggs, lightly beaten

¼ cup vegetable oil

Salt and freshly ground black pepper, to taste

1. Using the large bowl fitted with the universal 's' blade process bread, garlic, chives, parsley and lemon until all ingredients are finely chopped. Season to taste with salt and pepper.
2. Dip chicken fillets in flour, egg and breadcrumb mixture. Repeat. Refrigerate for 10 minutes.
3. Heat oil in a large frypan over medium heat. Add chicken in batches and cook for 4-5 minutes on each side or until golden brown and cooked. Serve immediately.

TIP: This chicken is great in sandwiches.

The Perfect Beef Patty

Makes: 10 patties

5 slices white bread

1kg rump steak

1 egg

1 onion

2 cloves garlic

2 tablespoons fresh flat- leaf parsley

2 tablespoons tomato sauce

1 tablespoon Worcestershire sauce

Salt and freshly ground black pepper, to taste

2 tablespoons oil

1. Using the large bowl fitted with the universal 's' blade process breadcrumbs until finely chopped. Set aside.
2. Add meat to the large processing bowl fitted with the large universal 's' blade and process until finely chopped. Add remaining ingredients and pulse until well combined. Season to taste with salt and pepper.
3. Form mixture into ½ cup patties. Refrigerate for 20 minutes.
4. Heat oil in a large frypan over medium heat. Cook patties for 3-4 minutes on each side or until golden brown and cooked.

TIP: The raw mixture can be formed into patties and frozen.

Mains/Sides/Soups continued

Roasted Pumpkin and Sweet Potato Soup

Makes: 8 cups

- 2 onions
- 500g carrot, peeled
- 500g sweet potato, peeled
- 2 tablespoons vegetable oil
- 2 cloves garlic
- 2 teaspoons ground cumin
- 1 teaspoon ground coriander
- 5 cups chicken stock
- 400g can chickpeas, drained, rinsed
- 1 tablespoon lemon juice
- Salt and freshly ground black pepper, to taste

1. Using the large bowl fitted with the variable slicing blade set to 3mm slice onion, carrot and potato.
2. Heat oil in a medium pot over medium heat. Add onion, carrot, potato and garlic cooking for 10-15 minutes or until softened.
3. Add spices and cook for 1-2 minutes or until fragrant. Add stock and chickpeas and simmer for 30 minutes or until vegetables are tender. Set aside to cool.
4. Using the large bowl fitted with large universal 's' blade process cooled soup in batches until smooth. Add lemon. Reheat soup before serving. Season to taste with salt and pepper.

Spicy Tomato and Lentil Soup

Makes: 10 cups

- 1 tablespoon olive oil
- 2 onions, chopped
- 2 cloves garlic, chopped
- 1 long red chilli, chopped
- 1 teaspoon ground chilli powder
- 1 teaspoon ground cumin
- 1 teaspoon ground turmeric
- ½ teaspoon sweet paprika
- 6 cups chicken stock
- 2 ¼ cups red lentils, washed
- 800g can chopped tomatoes
- Salt and freshly ground black pepper, to taste
- Fresh coriander and Greek yoghurt, to serve

1. Heat oil in a large pan over medium heat. Add onion, garlic and chilli, cooking until tender. Add spices and cook for 1-2 minutes or until fragrant.
2. Add remaining ingredients and bring to a simmer for 1 hour or until lentils are cooked. Allow soup to cool.
3. Using the large bowl fitted with universal 's' blade process cooled soup in batches until smooth. Season to taste with salt and pepper. Garnish with fresh coriander and a dollop of Greek yoghurt.

Mains/Sides/Soups continued

Broccoli, Spinach and Blue Cheese Soup

Makes: 8 cups

- 2 tablespoons olive oil
- 2 onions, chopped
- 2 potatoes, peeled, chopped
- 7 cups chicken stock
- 2 heads broccoli, chopped
- 500g baby spinach
- 150g blue cheese
- Salt and freshly ground black pepper, to taste

1. Heat oil in a medium saucepan over medium heat. Add onions cooking until tender.
2. Add potato and chicken stock cooking until potato is tender. Add broccoli and spinach cooking for a further 2 minutes or until broccoli is cooked. Allow soup to cool.
3. Using the large bowl fitted with the large universal 's' blade process cooled soup in batches until smooth. Season to taste with salt and pepper.
4. Reheat soup and crumble over blue cheese. Serve.

Caramelized Onion, Olive and Goats Cheese Tart

Makes: 1 tart

- 1 recipe short crust pastry
- 1 tablespoon olive oil
- 4 onions
- 1 tablespoon balsamic vinegar
- 2 eggs
- ½ cup milk
- ½ cup thickened cream
- 150g goat's cheese
- Salt and freshly ground black pepper, to taste

1. Preheat oven to 180C. Grease a 23cm tart tin.
2. Roll pastry out into a 26cm circle and gently place in tart tin. Cover with baking paper and fill with uncooked rice. Bake for 10 minutes. Remove baking paper and cook for a further 10 minutes or until base is golden.
3. Using the large bowl fitted with the variable slicing blade set to 3mm thick and slice onions.
4. Heat oil in a medium saucepan over medium heat. Add onion and vinegar, cooking for 10-15 minutes or until caramelized.
5. In a small bowl combine eggs, milk and cream. Season to taste with salt and pepper.
6. Spread onion and cheese evenly over the pastry. Pour over cream mixture.
7. Bake for 20-25 minutes or until cooked. Serve hot or cold.

Mains/Sides/Soups continued

Easy Pork Dumplings

Makes: 30 approximately

- 500g pork loin
- 1 bunch fresh chives
- 1 clove garlic
- 2 tablespoons rice wine vinegar
- 1 tablespoon corn flour
- 2 teaspoons dark soy sauce
- 1 teaspoon sesame oil
- 1 packet dumpling wrappers
- 1 tablespoon water
- Salt and freshly ground black pepper, to taste

1. Using the large processing bowl fitted with the large universal 's' blade process pork, chives, garlic, rice wine, corn flour, soy sauce and sesame oil until a smooth paste.
2. Place a tablespoon of pork mixture into the middle of each dumpling wrapper. Wet two sides of the wrapper with the water and fold in half making sure the dumpling is sealed tightly. Repeat.
3. Bring a pot of water to the boil. Line the base of a steaming basket with baking paper. Place dumplings in basket and cover steaming for 10-15 minutes or until cooked. Repeat.

TIP: Once the dumplings are steamed, fry off in a hot frypan for 1-2 minutes or until golden.

Fish Cakes

Makes: 10

- 1kg Sebago potatoes, peeled, chopped
- 600g salmon fillet, skinned, deboned
- 6 long green onions
- 2 tablespoons fresh dill
- 1 ½ teaspoons lemon rind
- ½ cup plain flour
- 1 egg
- 2 cups panko bread crumbs
- Salt and freshly ground black pepper, to taste
- Vegetable oil, for frying

1. Place potatoes in a medium pot and cover with water. Cook for 15-20 minutes or until cooked. Drain and lightly mash.
2. Using the large processing bowl fitted with the large universal 's' blade process salmon, green onions, dill and lemon until a chunky paste has formed.
3. Combine salmon mixture and potatoes. Season to taste with salt and pepper.
4. Form salmon mixture into ½ cup patties. Refrigerate for 10 minutes.
5. Dip salmon cakes into flour, egg then panko breadcrumbs. Repeat.
6. Heat 1cm of oil in a large frypan over medium heat. Cook salmon cakes in batches for 3-4 minutes on each side or until cooked and golden brown. Serve hot with tartare sauce.

Mains/Sides/Soups continued

Chicken Korma with Riata

Serves: 4-6

- 4 cloves garlic
- 1 onion
- 2cm piece ginger, peeled
- $\frac{3}{4}$ cup flaked almonds
- $\frac{2}{3}$ cup water
- 1 tablespoon ground coriander
- 1 tablespoon ground cumin
- $\frac{1}{4}$ teaspoon chilli powder
- $\frac{1}{3}$ cup vegetable oil
- 8 cardamom pods
- 4 cloves
- 2 bay leaves
- 1 cinnamon stick
- 1 tablespoon tomato puree
- 2 teaspoons garam masala
- $\frac{1}{3}$ cup double cream
- 1.5kg chicken thighs, skin removed
- Salt and freshly ground black pepper, to taste
- Rice, to serve

1. Using the small processing bowl with the small universal 's' blade process garlic, onion, ginger, almonds, water, coriander, cumin and chili powder until a smooth paste.
2. Heat oil in a large saucepan over medium heat. Add cardamom, cloves, bay leaves and cinnamon cooking for 1-2 minutes or until fragrant. Add spice paste and cook for a further 1-2 minutes.
3. Stir through tomato puree, garam masala and cream. Season to taste with salt and pepper.

4. Add chicken and coat in sauce. Bring to a simmer and cook for 20-25 minutes or until chicken is cooked. Serve with steamed rice.

Mains/Sides/Soups continued

Oven Baked Hot Chips

Serves: 3-4

- 1.5kg coliban potatoes, washed
- ¼ cup vegetable oil
- 2 tablespoons chopped fresh rosemary
- 1 tablespoon sea salt
- Salt and freshly ground black pepper, to taste

1. Preheat oven to 180°C. Line a baking tray with baking paper.
2. Using the large bowl fitted with the variable slicing blade set to 3mm and slice potatoes.
3. Toss potatoes with oil, rosemary and salt. Spread out over baking tray and bake for 30-40 minutes, stirring occasionally, or until golden and tender. Serve hot.

Chorizo and Basil Pizza

Makes: 2 pizzas

- 1 basic pizza dough, rolled into 2 26cm circles
- 1 cup tomato sauce
- 200g mozzarella
- 2 chorizo sausages
- 1 bunch fresh basil
- ¼ cup pine nuts, roasted
- 1 clove garlic
- ¼ cup olive oil
- Salt and freshly ground black pepper, to taste
- Fresh basil leaves, for garnish

1. Preheat oven to 200°C. Line two baking trays with baking paper. Place pizza bases on prepared trays.
2. Using the large processing bowl fitted with the variable slicing blade set to 2mm slice mozzarella and chorizo.
3. Spread tomato sauce over pizza bases. Top with chorizo and mozzarella. Place in oven and bake for 15-20 minutes or until the bases are cooked and the cheese has melted.
4. Meanwhile in the small bowl fitted with the small universal 's' blade add the remaining ingredients and pulse until a chunky paste. Season to taste with salt and pepper.
5. Dollop pesto over the cooked pizzas and top with fresh basil leaves.

Sweets and Desserts

White Chocolate and Raspberry Cheesecake

Serves: 8-10

200g digestive biscuits

80g butter, melted

500g cream cheese, room temperature

180g white chocolate, melted

1 cup thickened cream

$\frac{2}{3}$ cup icing sugar

$\frac{1}{4}$ cup boiling water

2 teaspoons powdered gelatine

$\frac{1}{2}$ cup frozen raspberries

100g white chocolate

2 cups frozen raspberries, thawed

1. Line a 23cm spring form pan with baking paper.
2. Using the large processing bowl fitted with the large universal 's' blade process biscuits and butter until a fine. Press into the base of the prepared pan.
3. Using the large processing bowl fitted with the large universal's' blade, process cream cheese, chocolate, cream and icing sugar until well combined.
4. Add gelatine to hot water, stir to combine. Add to the cream cheese mixture and process.
5. Pour into the prepared pan and dot the top with the frozen raspberries, pushing some down into the mixture. Refrigerate for 3 hours or until set.
6. Using large processing bowl fitted with the shaving blade process chocolate to form long shards.
7. Remove cheesecake from pan once chilled. Top with raspberries and white chocolate shards.

Buttermilk Pancakes

Serves: 3-4

1 cup buttermilk

1 cup self raising flour

2 tablespoons caster sugar

$\frac{1}{2}$ teaspoon bicarbonate of soda

1 egg, lightly beaten

60g butter, melted

Butter, for cooking

1. Using the large processing bowl with the universal 's' blade add all ingredients and process or 1 minute or until a smooth batter.
2. Heat butter in a large non-stick pan over medium heat. Add $\frac{1}{4}$ cup of batter to the pan and cook for 2-3 minutes on each side or until golden brown and cooked. Repeat. Serve hot with lemon curd.

Sweets and Desserts continued

Lemon Curd

Makes: 3 cups

115g butter, room temperature

1 ½ cups caster sugar

¼ lemon zest

4 eggs

½ cup lemon juice

1. Using the large processing bowl fitted with the large universal 's' blade process butter, sugar and lemon zest until combined.
2. Add eggs one at a time making sure to mix well after each addition, add lemon juice. Process until combined.
3. Pour mixture into a medium pot over medium heat and stir constantly until mixture has thickened, 5-10 minutes.
4. Store in a clean, covered container in the refrigerator for up to one week.

Orange Ricotta Torte

Serves: 8-10

125g blanched almonds

115g butter, room temperature

¾ cup caster sugar

4 eggs, separated

¼ cup plain flour

125g ricotta

1 tablespoon orange zest

50g dark chocolate

1. Preheat oven to 180°C. Grease and line a 20cm spring form cake pan with baking paper.
2. Place almonds on a baking tray and roast for 5 minutes or until golden. Allow to cool.
3. Once cooled using the small processing bowl fitted with the small universal's' blade process almonds until a fine powder. Set aside.
4. Using the large processing bowl fitted with the large universal 's' blade process the butter and sugar until pale, scraping down sides if necessary. Add egg yolks, one at a time, making sure to mix well after each addition. Sift over flour and gently fold through ricotta, orange zest and almond meal.
5. Using an electric mixer whisk egg whites until stiff peaks form.
6. Gently fold egg whites through ricotta mixture. Pour into prepared pan and bake for 25-30 minutes or until cooked. Allow to cool in pan before turning out onto a wire rack.
7. Using the large bowl with the fine grating blade grate the dark chocolate. Sprinkle over the top of cake just before serving.

Sweets and Desserts continued

Basic Butter Cake

Serves: 8-10

185g butter, room temperature

1 cup caster sugar

½ teaspoon vanilla essence

3 eggs

2 cups self-raising flour

¼ cup milk

1. Preheat oven to 180°C. Grease and line a 23cm cake pan.
2. Using the large processing bowl fitted with the large universal 's' blade, process butter, sugar and vanilla until well combined. Scraping down the sides of the bowl if necessary.
3. Add eggs to the mixture and process until combined. Add the flour and milk and continue to process until just combined.
4. Pour mixture into a prepared cake pan. Bake for 40-50 minutes or until cooked.
5. Allow to cool in the pan before turning onto a wire rack.

Moist Date and Walnut Cake

Serves: 8-10

300g dates, deseeded

1 teaspoon bicarbonate soda

1 ½ cups hot water

125g butter, room temperature

⅔ cup brown sugar

1 teaspoon vanilla essence

2 eggs

2 cups self raising flour

1 cup walnuts, chopped

1. Preheat oven to 180°C. Grease and line a 22cm cake pan with baking paper.
2. Using the small processing bowl fitted with the small universal 's' blade add dates, bicarbonate soda and water. Set aside for 10 minutes.
3. Using the large processing bowl fitted with the large universal 's' blade process the butter, sugar and vanilla until light and creamy. Scraping down the sides of the bowl if necessary.
4. Add eggs, one at a time, making sure to mix well after each addition.
5. Process date mixture until smooth. Add to butter mixture with flour and walnuts. Stir to combine.
6. Pour mixture into prepared pan and bake for 40-45 minutes or until cooked. Turn cake out onto wire rack to cool.

Sweets and Desserts continued

Upside down Pineapple Cake

Serves: 8-10

¼ cup brown sugar

125g butter, room temperature

425g can pineapple slices, ¼ cup juice reserved

¼ cup glace cherries

¾ cup self raising flour

⅔ cup caster sugar

¼ teaspoon bicarbonate soda

2 eggs

1. Preheat oven to 200°C. Grease and line a 23cm cake pan with baking paper.
2. Sprinkle brown sugar and 25g of the butter over the base of the pan. Top with pineapple rings and cherries.
3. Using the large processing bowl fitted with the large universal 's' blade process the remaining ingredients and reserved pineapple juice.
4. Pour mixture into the prepared pan and bake for 30 minutes or until cooked. Remove from pan while still warm.

Super Moist Chocolate Cake

Serves: 8-10

200g dark chocolate

175g butter, room temperature

⅔ cup brown sugar

100g blanched almonds

½ cup cocoa powder

4 eggs

1 cup self raising flour

100g milk chocolate chips

1. Preheat oven to 160°C. Grease and line a 22cm cake pan with baking paper.
2. Using the large processing bowl fitted with the large universal 's' blade process dark chocolate, butter, sugar, almonds and cocoa until smooth.
3. Add eggs one at a time, making sure to mix well after each addition. Add remaining ingredients and process until smooth.
4. Pour mixture into the prepared pan and bake for 45-45 minutes or until cooked. Allow to cool in pan for 10 minutes before turning out onto a wire rack.

Sweets and Desserts continued

Banana Cake with Cream Cheese Icing

Serves: 8-10

160g butter, melted

1 ½ cups mashed banana

1 cup caster sugar

¾ cup sour cream

½ cup brown sugar

2 eggs

1 ½ cups plain flour

2 teaspoons baking powder

1 teaspoon salt

½ teaspoon baking soda

1. Preheat oven to 180°C. Grease and line a 20cm cake pan with baking paper.
2. Using the large processing bowl fitted with the large universal 's' blade process butter, banana, sour cream, sugars and eggs until smooth.
3. Add remaining ingredients and pulse until just combined.
4. Pour into prepared pan and bake for 50-55 minutes or until golden and cooked. Allow to cool in the pan for 10 minutes before turning out onto a wire rack.
5. Once the cake has cooled, spread the sides and top of the cake with cream cheese icing.

Cream Cheese Icing

Makes: 3 cups

500g cream cheese, room temperature

100g butter, room temperature

2 teaspoons vanilla essence

1 ½ cups icing sugar

1. Using the large processing bowl fitted with the large universal 's' blade process cream cheese, butter and vanilla. Gradually add the icing sugar. Process until smooth.
2. This icing can be refrigerated in a clean airtight container for up to one week.

Sweets and Desserts continued

Fudge Balls

This is a great recipe for the kids to get involved.

Makes: 30 approximately

180g butter, melted

$\frac{3}{4}$ cup brown sugar

500g malt biscuits

$\frac{1}{2}$ cup milk

$\frac{1}{3}$ cup cocoa powder

1 teaspoon vanilla essence

Cocoa, to serve

1. In a small saucepan over medium heat melt butter and sugar. Stir constantly until sugar has dissolved. Set aside.
2. Using the large bowl fitted with the large universal 's' blade, process biscuits until a fine crumb.
3. Place all ingredients in a large bowl and stir to combine.
4. Form mixture into 1 tablespoon sized balls. Dust with extra cocoa if desired. Refrigerate for 2 hours before serving.

TIP: For adults add a tablespoon of your favourite liquor.

Dark Chocolate Pistachio Hedgehog Slice

220g packet chocolate cookies

80g butter, melted

100g dark chocolate, melted

$\frac{1}{3}$ cup cocoa powder

$\frac{1}{3}$ cup shredded coconut

1 tablespoon golden syrup

1 egg

$\frac{2}{3}$ cup pistachio kernels

Chocolate Topping:

200g dark chocolate

50g butter

1. Grease 17cm x 27cm pan and line with baking paper.
2. Using the large processing bowl fitted with the large universal 's' blade process cookies, butter, chocolate, cocoa, coconut, golden syrup and egg. Add pistachios and pulse until pistachios are roughly chopped.
3. Press mixture into prepared pan and refrigerate for 1 hour.
4. For the topping: in a small pot over medium heat, melt chocolate and butter.
5. Pour over slice and refrigerate until firm. Cut into squares.

Sweets and Desserts continued

Chocolate Chip Cookies

Makes: 24

125g butter, room temperature

½ cup brown sugar

½ cup caster sugar

¼ teaspoon vanilla essence

1 egg

1¾ cups self-raising flour

1 cup milk chocolate chips

½ cup white chocolate chips

¼ teaspoon salt

1. Preheat oven to 180°C and grease oven trays.
2. Using the large processing bowl fitted with the large universal 's' blade process butter, sugars and vanilla until well combined. Scraping down sides of the bowl if necessary.
3. Add egg to the mixture and continue to process until mixed. Add flour, chocolate chips and salt processing until just combined.
4. With a tablespoon, form mixture into small balls and place onto tray, allowing room for spreading.
5. Bake for 15 minutes or until cooked. Allow to cool on trays.

Lime and Mint Granita

Makes: 4-6

4 lemons

¼ cup fresh mint leaves

4 cups water

¼ cup caster sugar

Fresh mint, to serve.

1. Peel lemons and remove any excess pith.
2. Using the large processing bowl fitted with the large universal 's' blade process the lemon and mint until smooth. Allow to sit for 10 minutes.
3. Strain the lemon mixture and heat in a small saucepan with water and sugar. Stir until sugar has dissolved.
4. Pour the mixture into a baking dish. Freeze for 1 hour, remove mixture and scrape with two forks to break up the ice. Repeat this process every 2 – 3 hours until ice shards have formed.
Serve in glasses with a sprig of fresh mint.

Notes



COMMERCIAL DESIGN GUARANTEED PERFORMANCE



The Sunbeam 10 Year Motor Guarantee

Sunbeam has built its reputation on manufacturing quality electrical appliances. Our Cafe Series® Food Processor is constructed from the highest quality materials. So much so, we guarantee our Food Processor motor for ten (10) years against faulty materials or manufacture. This guarantee is just another expression of our confidence in the way we make appliances at Sunbeam. In order to be eligible for this guarantee, you must retain your receipt as proof of purchase.

Your Cafe Series® Food Processor is covered for the first year against faulty material or manufacture by the Sunbeam 12 Month Replacement Guarantee. Should you experience any difficulties with your appliance within this 12 Month period, please phone our customer service line for advice on 1300 881 861 in Australia, or 0800 786 232 in New Zealand.

The Sunbeam (10) ten year motor guarantee begins from date of purchase and extends for nine years beyond the 12 Month Replacement Guarantee. It covers only the motor, guaranteeing it against faulty materials or manufacture. It does not cover damage caused by accident, misuse or being used in a manner not in accordance with the Instruction Book. Similarly, this motor guarantee does not cover freight or any other costs incurred in making a claim.

If a fault should develop with the motor after the period covered by the 12 Month Replacement Guarantee, please call Sunbeam Customer Service on the number listed below or send a written claim to Sunbeam at the address listed below. On receipt of your claim, Sunbeam will advise you on how to obtain a replacement motor if your motor is defective. Alternatively, you can return the Cafe Series® Food Processor to any of Sunbeam's authorised service centres, together with your receipt. The service centre will examine the motor and if it is faulty or defective, the motor will be replaced free of charge.

For a complete list of Sunbeam's authorised service centres visit our website or call:

Sunbeam Corporation Ltd. Australia

www.sunbeam.com.au

1300 881 861

Units 5 & 6, 13 Lord Street
Botany NSW 2019 Australia

Sunbeam Corporation Ltd. New Zealand

www.sunbeam.co.nz

0800 786 232

26 Vestey Drive, Mt Wellington
Auckland, New Zealand

The benefits given to you by this guarantee are in addition to your other rights and remedies under any laws which relate to the appliance.

Our goods come with guarantees that cannot be excluded under the Australian Consumer Law and under the New Zealand Consumer Guarantees Act. In Australia you are entitled to a replacement or refund for a major failure and for compensation for any other reasonably foreseeable loss or damage. You are also entitled to have the goods repaired or replaced if the goods fail to be of acceptable quality and the failure does not amount to a major failure.

IMPORTANT NOTE

Sunbeam agrees to replace the motor in the event of the motor developing a fault or defect, within the four years after the 12 Month Replacement Guarantee.

As your Cafe Series® Food Processor needs to be assessed at a Sunbeam authorised service centre, it will not be accepted through retail stores.

If using the Cafe Series® Food Processor for commercial use this motor guarantee is limited to 12 months from the date of purchase.



COMMERCIAL DESIGN GUARANTEED PERFORMANCE

12 Month Replacement Guarantee

In the unlikely event that this appliance develops any malfunction within 12 months of purchase (3 months commercial use) due to faulty materials or manufacture, we will replace it for you free of charge.

Should you experience any difficulties with your appliance, please phone our customer service line for advice on 1300 881 861 in Australia, or 0800 786 232 in New Zealand. Alternatively, you can send a written claim to Sunbeam at the address listed below. On receipt of your claim, Sunbeam will seek to resolve your difficulties or, if the appliance is defective, advise you on how to obtain a replacement or refund.

Your Sunbeam 12 Month Replacement Guarantee naturally does not cover misuse or negligent handling and normal wear and tear.

Similarly your 12 Month Replacement Guarantee does not cover freight or any other costs incurred in making a claim. Please retain your receipt as proof of purchase.

The benefits given to you by this guarantee are in addition to your other rights and remedies under any laws which relate to the appliance.

Our goods come with guarantees that cannot be excluded under the Australian Consumer Law and under the New Zealand Consumer Guarantees Act.

In Australia you are entitled to a replacement or refund for a major failure and for compensation for any other reasonably foreseeable loss or damage. You are also entitled to have the goods repaired or replaced if the goods fail to be of acceptable quality and the failure does not amount to a major failure.

Should your appliance require repair or service *after* the guarantee period, contact your nearest Sunbeam service centre.

For a complete list of Sunbeam's authorised service centres visit our website or call:

Australia

www.sunbeam.com.au

1300 881 861

Units 5 & 6, 13 Lord Street
Botany NSW 2019 Australia

New Zealand

www.sunbeam.co.nz

0800 786 232

26 Vestey Drive, Mt Wellington
Auckland, New Zealand



COMMERCIAL DESIGN GUARANTEED PERFORMANCE

Need help with your appliance?

Contact our customer service team or visit our website for information and tips on getting the most from your appliance.

In Australia

Visit www.sunbeam.com.au

Or call 1300 881 861

In New Zealand

Visit www.sunbeam.co.nz

Or call 0800 786 232

Sunbeam is a registered trademark.

'Cafe Series' is a registered trademark of Sunbeam Corporation.

Made in China.

Due to minor changes in design or otherwise, the product may differ from the one shown in this leaflet.

© Copyright. Sunbeam Corporation Limited 2011.

ABN 45 000 006 771

Units 5 & 6, 13 Lord Street
Botany NSW 2019 Australia

Unit 3, Building D
26 Vestey Drive
Mt Wellington Auckland
New Zealand

Sunbeam Corporation is a division of GUD Holdings Ltd.